

- PFI wiring diagram Notes**
1. One six pin connector.
  2. Two three pin connectors.
  3. Connect Gnd lead directly to Bat
  4. Connect +12Bat directly to Bat
  5. Connect +12VDC to ign switch.
  6. Connect purple to black wire on fuel pump.
  7. IGN2 wire color is white.

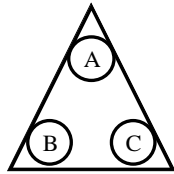

**3 Pin Connector**  
 Pinout:  
 A- V+  
 B- Gnd  
 C- Signal

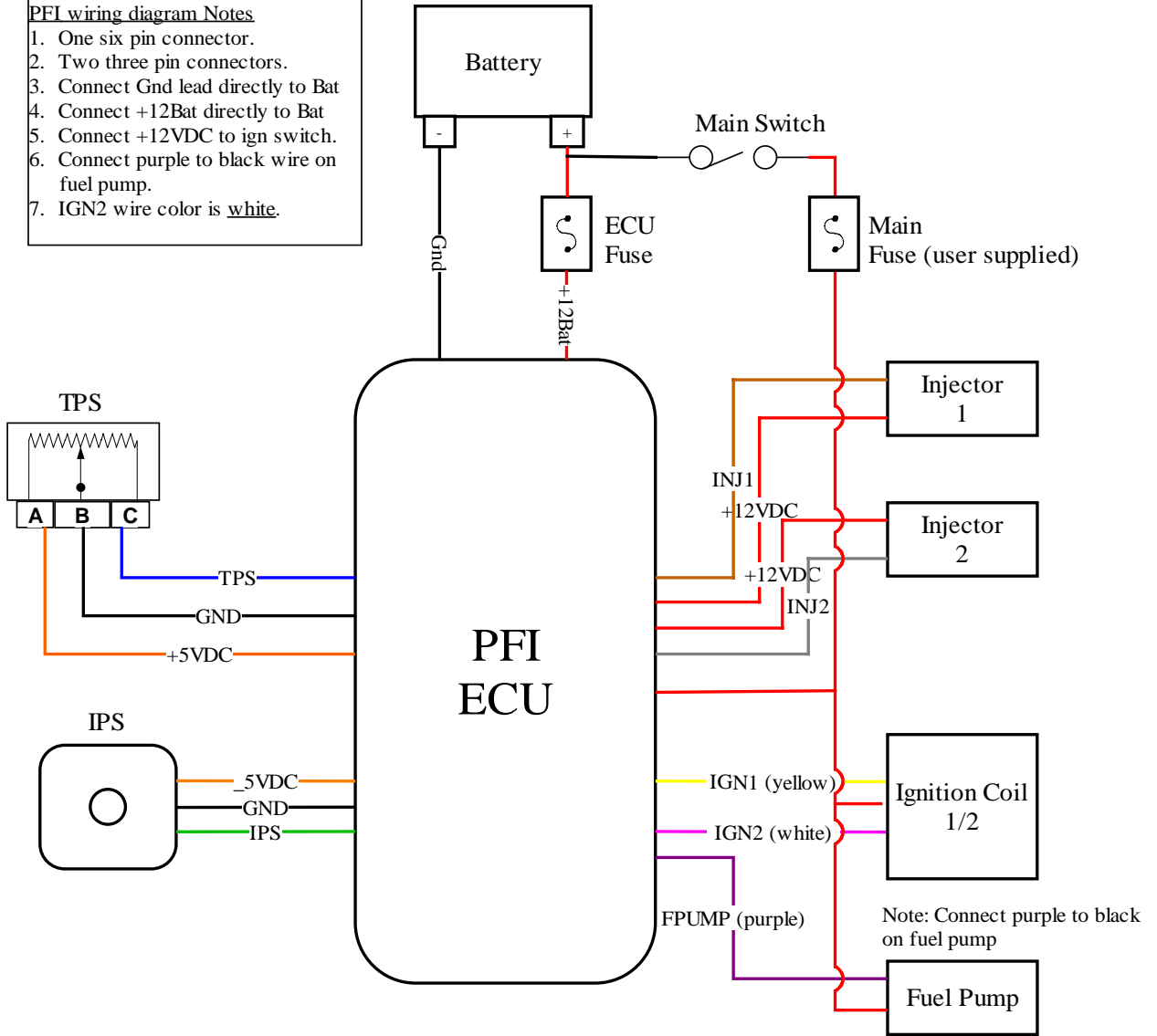
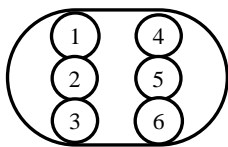

**6 Pin Connector**  
 Pinout:  
 1- V+ Bat  
 2- V+ Switch  
 3- Fuel Pump  
 4- Ign1  
 5- Ign2

**ECU Wire Color Code**

Red/w- V+ Bat
Red Switch
Blk- Ground
Orange- +5 VDC
White- Ign2
Yellow- Ign1
Grey- Inj2
Brn- Inj1
Purple- FPump
Green- IPS
Blue- TPS

